

Safety Standard Certified Resin Molding SMD Type Ceramic Capacitors for General Purpose SYW Series (Y1:250V~/400V~)	POE-D31-00-E-15	Ver: 15	Page: 1 / 14
---	-----------------	---------	--------------

HF

PRODUCT SPECIFICATION

Safety Standard Certified Resin Molding
PRODUCT: SMD Type Ceramic Capacitors for General Purpose

TYPE: SYW SERIES (Y1:250V~/400V~)
100J~222M

CUSTOMER: _____
DOC. NO.: **POE-D31-00-E-15**
N.W.: **0.24~0.29g/pc**

APPROVED BY CUSTOMER

VENDOR :

- WALSIN TECHNOLOGY CORPORATION**
566-1, KAO SHI ROAD, YANG-MEI
TAO-YUAN, TAIWAN
- PAN OVERSEAS (GUANGZHOU) ELECTRONIC CO., LTD.**
NO.277, HONG MING ROAD, EASTERN SECTION, HUANGPU DISTRICT,
GUANG ZHOU, CHINA
- DONGGUAN WALSIN TECHNOLOGY ELECTRONICS CO., LTD.**
NO.638, MEI JING WEST ROAD, XINIUPO, ADMINISTRATIVE ZONE, DAL
ANGTOWN, DONGGUAN CITY, GUANGDONG PROVINCE

PSA

Safety Standard Certified Resin Molding SMD Type Ceramic Capacitors for General Purpose SYW Series (Y1:250V~/400V~)	POE-D31-00-E-15	Ver: 15	Page: 2 / 14
---	-----------------	---------	--------------

Record of change

Date	Version	Description	page
2021/1/7	00	First edition.	All
2021/6/30	01	Add "HF" logo	1
2021/8/26	02	Update 5.2 Safety standards approval and recognized no. 6. Specification and test method 11. Soldering Recommendation	7 8~10 16
2021/9/2	03	Update 5.2 Safety standards approval and recognized no.	7
2021/9/6	04	Update 5.2 Safety standards approval and recognized no.	7
2021/10/28	05	Update 6. Specification and test method	8~10
2021/12/21	06	Update 6. Specification and test method	8~10
2022/4/19	07	Add 4. Marking: Date code comparison table	6
2022/6/7	08	Update 7. Packing Description	11
2022/6/27	09	Update 2. Mechanical Add 3. Part number YPSYW271KP00 Update 5.4 Product Structure Update 6. Specification and test method Add 7.3 Peeling off force Update 8.1 Soldering Land Pattern Size Update 9&10	5~13
2023/9/12	10	Update 9. Storage conditions	13
2023/10/24	11	Add 150pF	5
2024/2/7	12	Update 5.2 Safety standards approval and recognized no.	7
2024/7/4	13	2. Mechanical dimension 5.2 Safety standards approval and recognized no. 5.4 Product Structure 6.2 Performance 7.1 Dimension of tape 8.2 Reflow Soldering 8.3 Wave Soldering	5 7 7 8~10 11 12
2024/10/8	14	6.2 Performance	8~10
2025/3/7	15	Update 2. Mechanical dimension tolerance 4. Marking: CQC logo 8.2 Reflow Soldering 8.3 Wave Soldering Add 5.3 Content of toxic and harmful substances control requirements 9 Capacitor temperature characteristic	5 6 12 7 13

Safety Standard Certified Resin Molding SMD Type Ceramic Capacitors for General Purpose SYW Series (Y1:250V~/400V~)	POE-D31-00-E-15	Ver: 15	Page: 3 / 14
---	-----------------	---------	--------------

Table of Contents

No.	Item	Page
1	Part number for SAP system	4
2	Mechanical	5
3	Part numbering/T.C/Capacitance/ Tolerance	5
4	Marking	6
5	Scope	7
6	Specification and test method	8~10
7	Packing Description	11
8	Soldering Recommendation	12~13
9	Capacitor temperature characteristic	13
10	Storage conditions	13
11	Application notes	14



Safety Standard Certified Resin Molding SMD Type Ceramic Capacitors for General Purpose SYW Series (Y1:250V~/400V~)	POE-D31-00-E-15	Ver: 15	Page: 4 / 14
---	-----------------	---------	--------------

1. Part number for SAP system:

(Ex.) YV S YW 222 M P 00
 (1) (2) (3) (4) (5) (6)

(1) Temperature characteristic (identified code)

CODE	Temperature characteristic	Cap. Change
SL	SL	-1000~+350PPM/°C (+20°C~+85°C)
YP	B (Y5P)	±10%
YU	E (Y5U)	-56% to +22%
YV	F(Y5V)	-82% to +22%

(2) SMD Type : SYW (Y1:250Vac/400Vac)

(3) Capacitance (identified by 3-figure code):ex. 221=220pF , 222=2200pF

(4) Capacitance tolerance (identified by code): J:±5%,K:±10%,M:±20%

(5) Special Specification Code :

Code	Description
P	Pb Solder Product

(6) Internal code: 00--Normal, other code--Special control



Safety Standard Certified Resin Molding SMD Type Ceramic Capacitors for General Purpose SYW Series (Y1:250V~/400V~)	POE-D31-00-E-15	Ver: 15	Page: 5 / 14
---	-----------------	---------	--------------

2. Mechanical: Encapsulation : Epoxy resin, flammability UL94 V-0

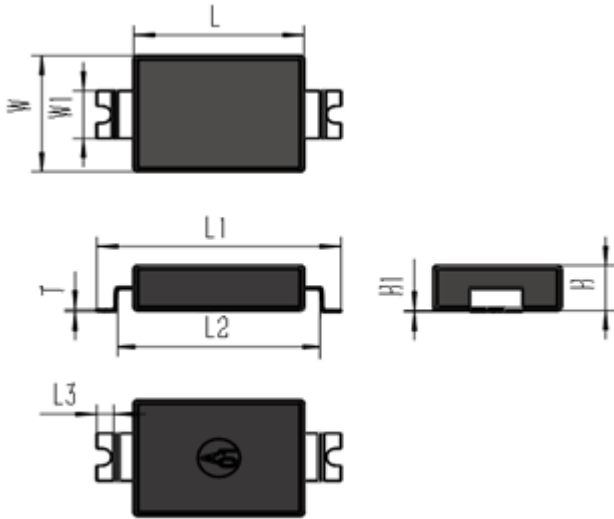





Dimension(mm)			
L	7.8±0.3	W1	2.5±0.1
W	5.4±0.3	T	0.13±0.05
H	2.45 max	H1	0.1+0.1/-0.05
L1	9.6±0.3	L3	0.4 min.
L2	8.4+0.5/-0.2 (medial measurement)		

3. Part numbering/T.C/Capacitance/ Tolerance :

SAP P/N	T.C.	Capacitance	Tolerance	Weight (g)
SLSYW100JP00	SL	10 pF	±5%	0.265
SLSYW220JP00		22 pF		0.251
SLSYW470JP00		47 pF		0.261
SLSYW680JP00		68 pF		0.256
YPSYW101KP00	Y5P	100 pF	±10%	0.266
YPSYW151KP00		150 pF		0.266
YPSYW221KP00		220 pF		0.273
YPSYW271KP00		270 pF		0.277
YPSYW331KP00		330 pF		0.281
YPSYW471KP00		470 pF		0.282
YUSYW471MP00	Y5U	470 pF	±20%	0.281
YUSYW681MP00		680 pF		0.271
YUSYW102MP00		1000 pF		0.275
YUSYW152MP00		1500 pF		0.277
YVSYW222MP00	Y5V	2200 pF	±20%	0.275

Safety Standard Certified Resin Molding SMD Type Ceramic Capacitors for General Purpose SYW Series (Y1:250V~/400V~)	POE-D31-00-E-15	Ver: 15	Page: 6 / 14
---	-----------------	---------	--------------

4. Marking:

1. Company Name Code(Trade mark)	UK
2. Type/Series Designation	SYW
3. Code of Dielectric	SL / B(Y5P) / E(Y5U) / F(Y5V)
4. Nominal Capacitance	Identified by 3-Figure Code. Ex. 470pF→"471", 1000pF→"102"
5. Capacitance Tolerance	J:±5%,K:±10%,M:±20%
6. Class code/Rated Voltage Mark	Y1 / 250V~ ;400V~
7. Safety certification mark	UL/cUL:  us ; ENEC:  ; CQC:  ; KC: 
8. Products ID (Manufactured Date code, add as needed)	Abbreviation ex.: NB210303 N:2021 year B: Sn-Pb-Ag Solder 21: Machine and batch (production line traceability) 03: March 03:date
Marking sample	
	

Date code comparison table:

code of year		code of month		code of day					
year	code	year	code	month	code	day	code	day	code
		2020	M	1	1	1	1	16	16
		2021	N	2	2	2	2	17	17
2010	A	2022	P	3	3	3	3	18	18
2011	B	2023	R	4	4	4	4	19	19
2012	C	2024	S	5	5	5	5	20	20
2013	D	2025	T	6	6	6	6	21	21
2014	E	2026	U	7	7	7	7	22	22
2015	F	2027	V	8	8	8	8	23	23
2016	H	2028	W	9	9	9	9	24	24
2017	J	2029	X	10	10	10	10	25	25
2018	K			11	11	11	11	26	26
2019	L			12	12	12	12	27	27
						13	13	28	28
						14	14	29	29
						15	15	30	30
								31	31

Safety Standard Certified Resin Molding SMD Type Ceramic Capacitors for General Purpose SYW Series (Y1:250V~/400V~)	POE-D31-00-E-15	Ver: 15	Page: 7 / 14
---	-----------------	---------	--------------

5. Scope:

THIS SPECIFICATION APPLIES TO CERAMIC INSULATED CAPACITORS RESIN MOLDING SMD TYPE USED IN ELECTRONIC EQUIPMENT.

5.1 Applicable safety standard

This specification applies to the UL/CUL, VDE/ENEC, CQC and KC approved ceramic capacitors resin molding SMD type for antenna coupling, line-by-pass and across-the-line. X1, Y1 capacitor based on IEC60384-14.

5.2 Safety standards approval and recognized no.

Safety Standard	Standard No.	Subclass	w.v.	Recognized No.
UL / CUL	ANSI/UL 60384-14	Y1	250Vac/400Vac	E146544
ENEC	EN 60384-14:2013/A1:2016	Y1	250Vac/400Vac	ENEC-03633-M1
CQC	GB/T6346.14	Y1	400Vac	CQC21001310797
KC	K60384-14	Y1	250Vac	SU03127-21001

5.3 Content of toxic and harmful substances control requirements

RoHS2.0 2011/65/EU · Halogen · REACH No1907/2006

5.4 Exemption Clause

2010/571/EU 7(a): Lead in high melting temperature type solders (i.e. lead-based alloys containing 85 % by weight or more lead)

5.5 Product Structure:

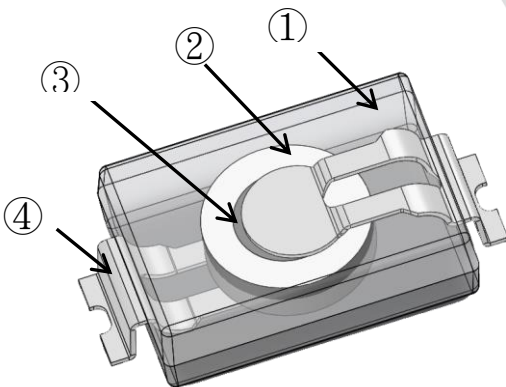

No.	Part name	Material
①	Coating	Epoxy molding compound (Conforming to UL94V-0 standard)
②	Chip	Ceramic chip
③	Solder	Sn-Pb-Ag Solder
④	Lead Pin	Copper alloy
		Tin coating

Safety Standard Certified Resin Molding SMD Type Ceramic Capacitors for General Purpose SYW Series (Y1:250V~/400V~)	POE-D31-00-E-15	Ver: 15	Page: 8 / 14
---	-----------------	---------	--------------

6. Specification and test method:

6.1 Operating Temperature Range: -40 to +125°C

6.2 Performance:

No	Items	Specification	Testing method												
1	Appearance and dimensions	No marked defect on appearance form and dimensions. Please refer to [Part number list].	The capacitor should be inspected by naked eyes for visible evidence of defect. Dimensions should be measured with slide calipers.												
2	Marking	To be easily legible.	The capacitor should be inspected by naked eyes.												
3	Voltage proof	No permanent break-down or flashover during the test period	Test voltage:4000VAC frequency:50/60Hz duration:60 seconds leakage current: 5mA max												
	Between lead wires														
	Body Insulation														
4	Capacitance	Within specified tolerance J: ±5% K: ±10% M: ±20%	Temperature:25±3°C Humidity: 55±30%RH Voltage: 1.0±0.2V Frequency:ClassI(SL) : 1±0.2MHZ ClassII(Y5P Y5U Y5V): 1±0.2KHZ												
5	Dissipation Factor(D.F.)	Char.	Temperature: 25±3°C Humidity: 55±30%RH Voltage: 1.0±0.2V Frequency: SL : 1±0.2MHZ Y5P Y5U Y5V: 1±0.2KHZ												
		Specifications													
		SL	1.5% max.												
		B(Y5P) E(Y5U) F(Y5V)	2.5% max.												
6	Temperature Characteristic	Char.	The capacitance measurement shall be made at each step specified in Table												
		Capacitance Change													
		SL	-1000~+350 (ppm/°C)												
		B(Y5P)	Within ± 10%												
		E(Y5U)	Within +22/-56%												
		F(Y5V)	Within +22/-82%												
			<table border="1"> <thead> <tr> <th>Step</th> <th>1</th> <th>2</th> <th>3</th> <th>4</th> <th>5</th> </tr> </thead> <tbody> <tr> <td>Temp.(°C)</td> <td>+20±2</td> <td>-25±2</td> <td>+20±2</td> <td>+85±2</td> <td>+20±2</td> </tr> </tbody> </table> $\Delta = (C_X - C_0) / C_0$ C _X : capacitor for step2,4 C ₀ capacitor for step 3	Step	1	2	3	4	5	Temp.(°C)	+20±2	-25±2	+20±2	+85±2	+20±2
Step	1	2	3	4	5										
Temp.(°C)	+20±2	-25±2	+20±2	+85±2	+20±2										
7	Insulation resistance	Between lead wires	10000MΩ MIN	The insulation resistance shall be measured with DC500±50V within 60±5s of charging. The voltage should be applied to the capacitor through a resistor of 1MΩ.											
		Body Insulation	10000MΩ MIN												
8	Solderability	Good tin coating (tin rate above 90%), within 3 seconds of convergence.	Immerse the capacitor in the solution of ethanol (JIS K 8101) and rosin (JIS K 5902) (25% rosin in weight proportion). (Reference) Temperature of solder : 245±10°C Immersion time: 2±0.5seconds												

Safety Standard Certified Resin Molding SMD Type Ceramic Capacitors for General Purpose SYW Series (Y1:250V~/400V~)	POE-D31-00-E-15	Ver: 15	Page: 9 / 14
---	-----------------	---------	--------------

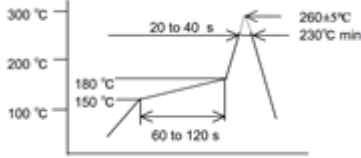
No	Items	Specification	Testing method
9	Soldering Heat Resistance	Appearance	No marked defect.
		I.R.	refer item 7
		voltage proof	refer item 3
		Dissipation factor	SL:≤1.0% Y5P:≤2.5% Y5U:≤2.5% Y5V:≤2.5%
		Capacitance Change	SL : Within±5% B(Y5P) : Within ±10% E(Y5U),F(Y5V) : Within ±20%
			<p>Reflow(peak temperature) : 260±5°C Solder zone : 230°C min. 20-40s.</p>  <p>Pre-treatment The capacitor should be stored at 125 ± 3°C for 1 hour and subjected to AC4000V (r.m.s.) for 60 seconds. Then, it should be left at room temperature for 24 ± 2 hours before initial measurement Post-treatment :Capacitor should be stored for 24±2h at *room condition.</p>
10	Vibration	Appearance	No marked defect.
11	Temperature cycle	Appearance	No marked defect.
		voltage proof	refer item 3
		Capacitance	SL:±5% Y5P: ±10% Y5U/Y5V: ±20%
		dissipation factor	SL:≤1.0% Y5P/Y5U/Y5V: ≤2.5%
		Insulation resistance	3000MΩ MIN
			<p>Pre-treatment :The capacitor should be stored at 125 ± 3°C for 1 hour and subjected to AC4000V (r.m.s.) for 60 seconds. Then, it should be left at room temperature for 24 ± 2 hours before initial measurement. Upper category temperature : +125±3°C Lower category temperature : -40±3°C Number of cycles :5 Duration of exposure at the temperature limits : 30minutes Capacitor shall be placed at 25±3°C for 24±2h before initial measurements.</p>
12	Impulse voltage	No permanent breakdown or flashover during the test period	Peak impulse voltage: 8.0KV Impulses distance : > 10 seconds Impulses times:24
		If any three successive impulses are shown by the oscilloscope monitor to have had a waveform indicating that no self-healing breakdowns or flashovers have taken place in the capacitor, then no further impulses shall be applied and the capacitor shall be counted as conforming.	
		If all 24 impulses have been applied to the capacitor and 3 or more of them are of a waveform indicating that no self-healing breakdowns or flashovers have occurred, then the capacitor shall be counted as conforming.	
		If less than three impulses are of the required waveform, then the capacitor shall be counted as a nonconforming item.	

Safety Standard Certified Resin Molding SMD Type Ceramic Capacitors for General Purpose SYW Series (Y1:250V~/400V~)	POE-D31-00-E-15	Ver: 15	Page: 10 / 14
---	-----------------	---------	---------------

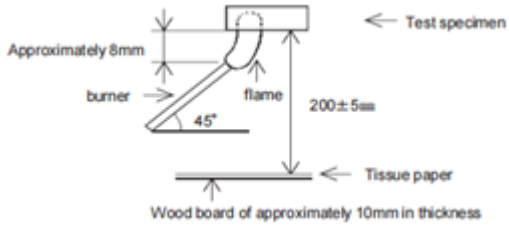
No	Items	Specification	Testing method
13	Endurance	Appearance	No marked defect.
		Capacitance Change	$\Delta=(C_x-C_0)/C_0$ SL:±5% Y5P: ±10% Y5U: ±15% Y5V: ±15%
		I.R.	≥3000MΩ
		voltage proof	Per Item 3
		dissipation factor	SL:≤1.0% Y5P/Y5U/Y5V: ≤5%
14	Damp heat steady state	Appearance	No marked defect.
		Capacitance Change	$\Delta=(C_x-C_0)/C_0$ SL:±5% Y5P: ±10% Y5U/Y5V: ±15%
		I.R.	≥3000MΩ
		voltage proof	Per Item 3
		dissipation factor	SL:≤1.0% Y5P/Y5U/Y5V: ≤5%
15	Passive flammability	The burning time should not be exceeded the time 10s. The tissue paper should not ignite	<p>The capacitor under test shall be held in the flame in the position which best promotes burning. Each specimen shall only be exposed once to the flame. Time of exposure to flame : 10 s.</p> <p>Length of flame : 12±1mm Gas burner : Length 35mm min. Inside dia : 0.5±0.1mm Outside dia : 0.9mm max. Gas : Butane gas purity 95% min.</p> 
16	Component solvent Resistance	No visible damage. Performance according Item 3~7	Solvent to be used:30±5%isopropyl alcohol and 70±5%fluxional compound Solvent temperature: 23±5℃ The capacitor shall be immersed in solvent for 5±0.5seconds Recovery time: 8hours
17	Solvent resistance of the marking	The marking shall be legible	Solvent to be used:30±5%isopropyl alcohol and 70±5%fluxional compound Solvent temperature: 23±5℃ The capacitor shall be immersed in solvent for 5±0.5seconds and its markshall be wiped with pledget for 10times.

Safety Standard Certified Resin Molding SMD Type Ceramic Capacitors for General Purpose SYW Series (Y1:250V~/400V~)	POE-D31-00-E-15	Ver: 15	Page: 11 / 14
---	-----------------	---------	---------------

7.Packing Description :

7.1 Dimension of tape

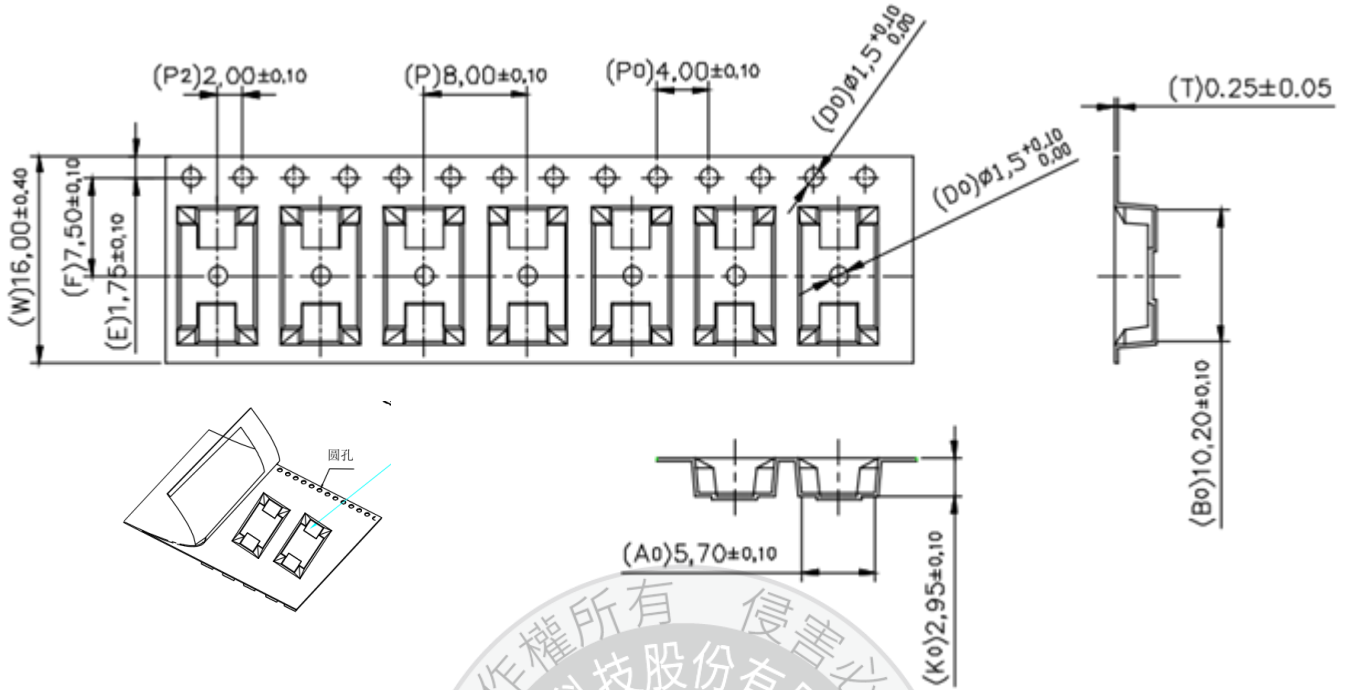

7.2 Reel Drawing

Q'ty/reel	reel size
3000pcs	13inch

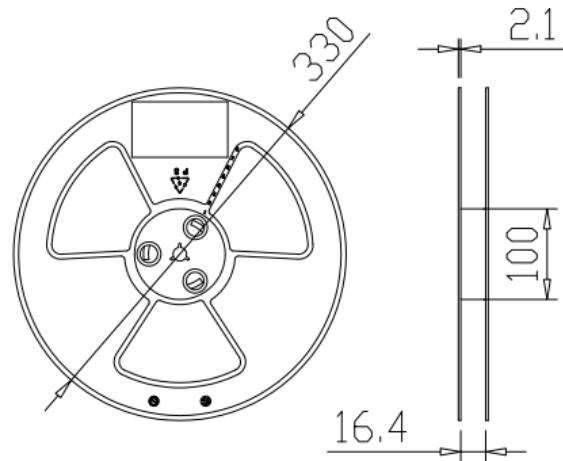
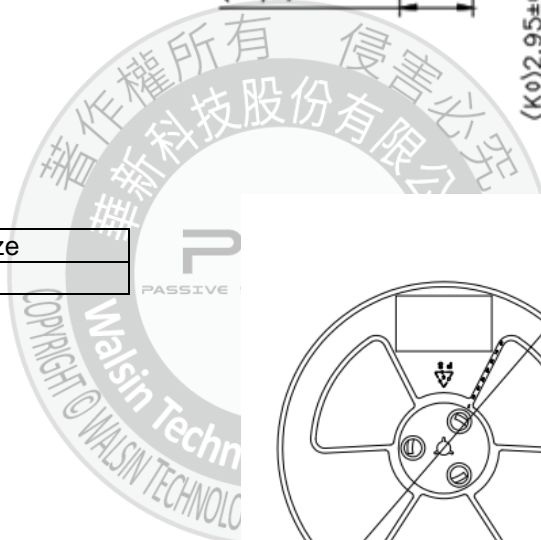

7.3 Peeling off force

Item	Data	Remark
Cover tape adhesion	10 ~ 100g	Carrier tape and cover tape open angle 165 ~ 180° F=300 ± 5mm/minute

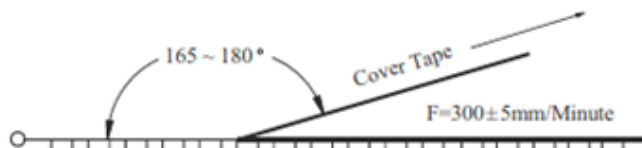

8. Soldering Recommendation:

8.1 Soldering Land Pattern Size:

The recommended solder pad dimensions for reflow soldering are as follows. "a" is to ensure the creepage distance required by the safety standard applied to your equipment.

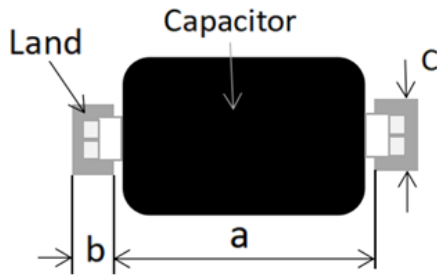

Dimension	a(mm)	b(mm)	c(mm)
7.8x5.4	8.0min	2.2±0.1	3.6±0.1

8.2 Reflow Soldering

When soldering capacitor, it should be performed in following conditions, and the continuous welding times should not exceed three times

Soldering temperature : 260±5°C.

Soldering time : 120s max.

Preheating temperature: 150°C max.

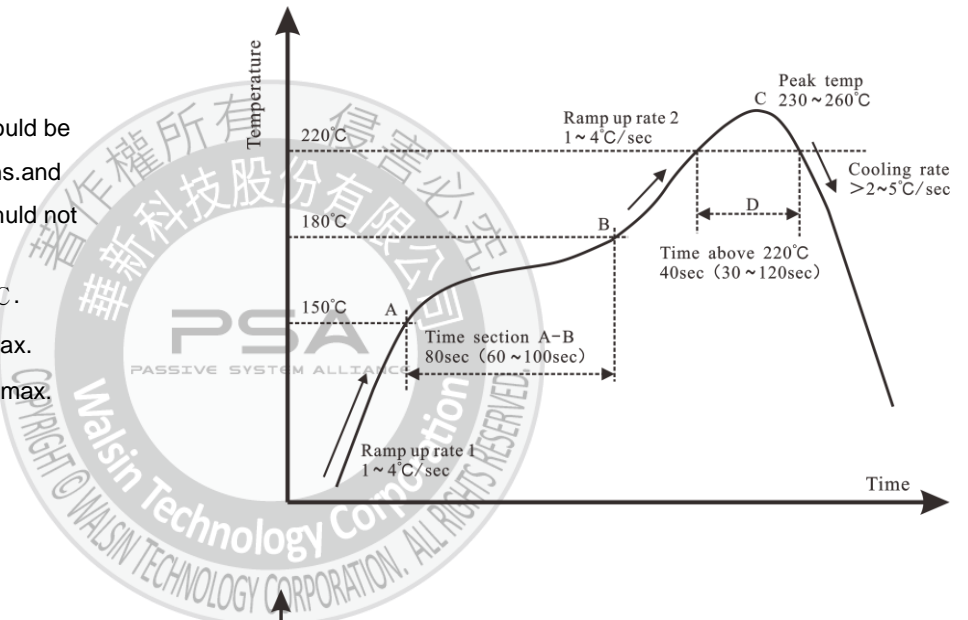

8.3 Wave Soldering

When soldering capacitor, it should be performed in following conditions, and the continuous welding times should not exceed three times.

Soldering temperature : 260±5°C

Soldering time : 10s max.

Preheating temperature: 100°C max.

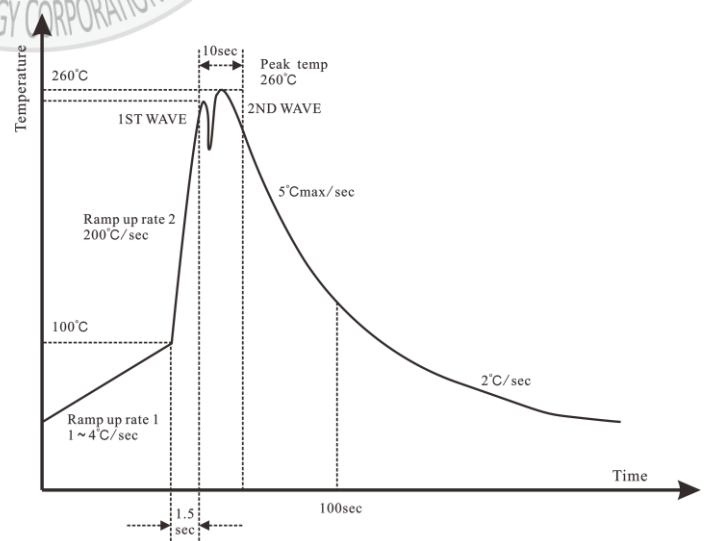

Safety Standard Certified Resin Molding SMD Type Ceramic Capacitors for General Purpose SYW Series (Y1:250V~/400V~)	POE-D31-00-E-15	Ver: 15	Page: 13 / 14
---	-----------------	---------	---------------

8.4 Soldering Iron

When soldering this product to a PCB/PWB, do not exceed the solder heat resistance specification of the capacitor. Subjecting this product to excessive heating could melt the internal junction solder and may result in thermal shocks that can crack the ceramic element.

When soldering capacitor with a soldering iron, it should be performed in following conditions.

Temperature of iron-tip : 400°C max.

Soldering iron wattage : 50W max.

Soldering time : 5s max.

9. Capacitor temperature characteristic

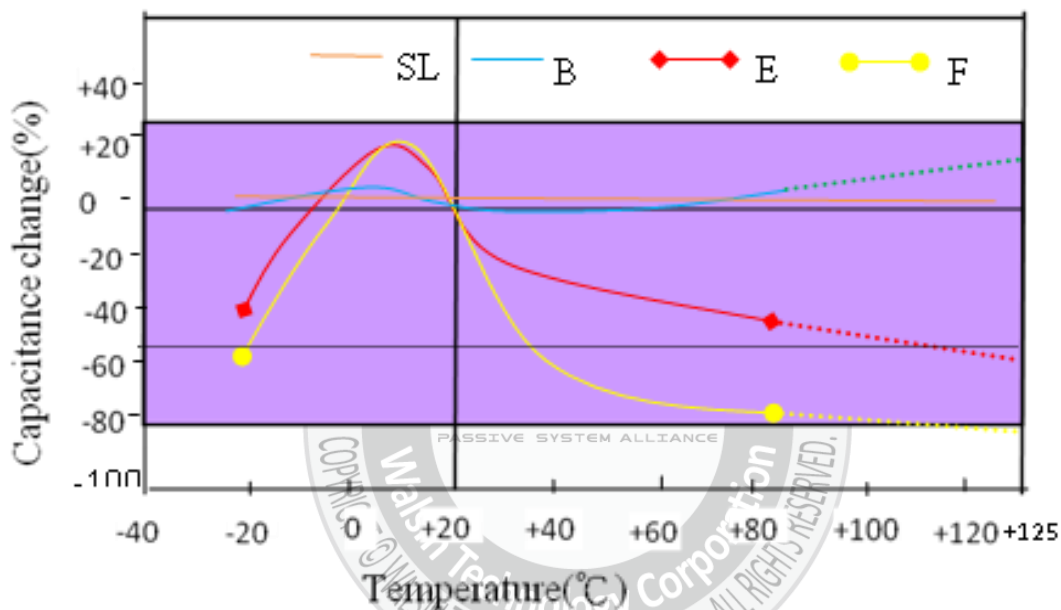

10. Storage conditions

10.1 The insulating Epoxy molded capacitors does not form a perfect seal; therefore, do not use or store capacitors in a corrosive atmosphere, especially where chloride gas, sulfide gas, acid, alkali, salt or the like are present. And avoid exposure to moisture. So, in order to avoid the absorption of moisture, capacitors are packed in moisture-proof envelope.

10.2 Store the capacitors in the following conditions at all times, and use within 12 months after delivered.

Temperature: 10 ~ 30°C

Humidity: 60%max.

10.3 Solder the enclosed capacitors within 168 hours after opening the moisture-proof package. After opening, store the capacitors in moisture-proof package with a desiccant and HIC card and keep the above condition.

10.4 In case the storage period has been exceeded 12 months or the indicator color of a enclosed HIC card has changed when the package has been opened, perform baking (60°Cx168hr) before soldering.

Safety Standard Certified Resin Molding SMD Type Ceramic Capacitors for General Purpose SYW Series (Y1:250V~/400V~)	POE-D31-00-E-15	Ver: 15	Page: 14 / 14
---	-----------------	---------	---------------

11 Application notes

11.1 Attention is drawn to the fact that repetition of the voltage proof test by the user may damage the capacitor.

11.2 Capacitors mounted on a printed circuit board (PCB) requirements of PCB board welding disc required and capacitor pin paste solder joint agreement, the opposite may cause the capacitor and the PCB board to bad welding and capacitor tube deform the feet or body destruction and damage the capacitor.

11.3 Avoid any compressive, tensile or flexural stress.

11.4 Please consult us first if you wish to embed the capacitor in plastic resins.

11.5 Do not move the capacitor after it has been soldered to the board.

11.6 Do not pick up the PC board by the soldered capacitor.

